

Aug.1.2021 Copyright 2021 HIROSE ELECTRIC CO., LTD. All Rights Reserved.  
 In case of consideration for using Automotive equipment / device which demand high reliability, kindly contact our sales window correspondents.

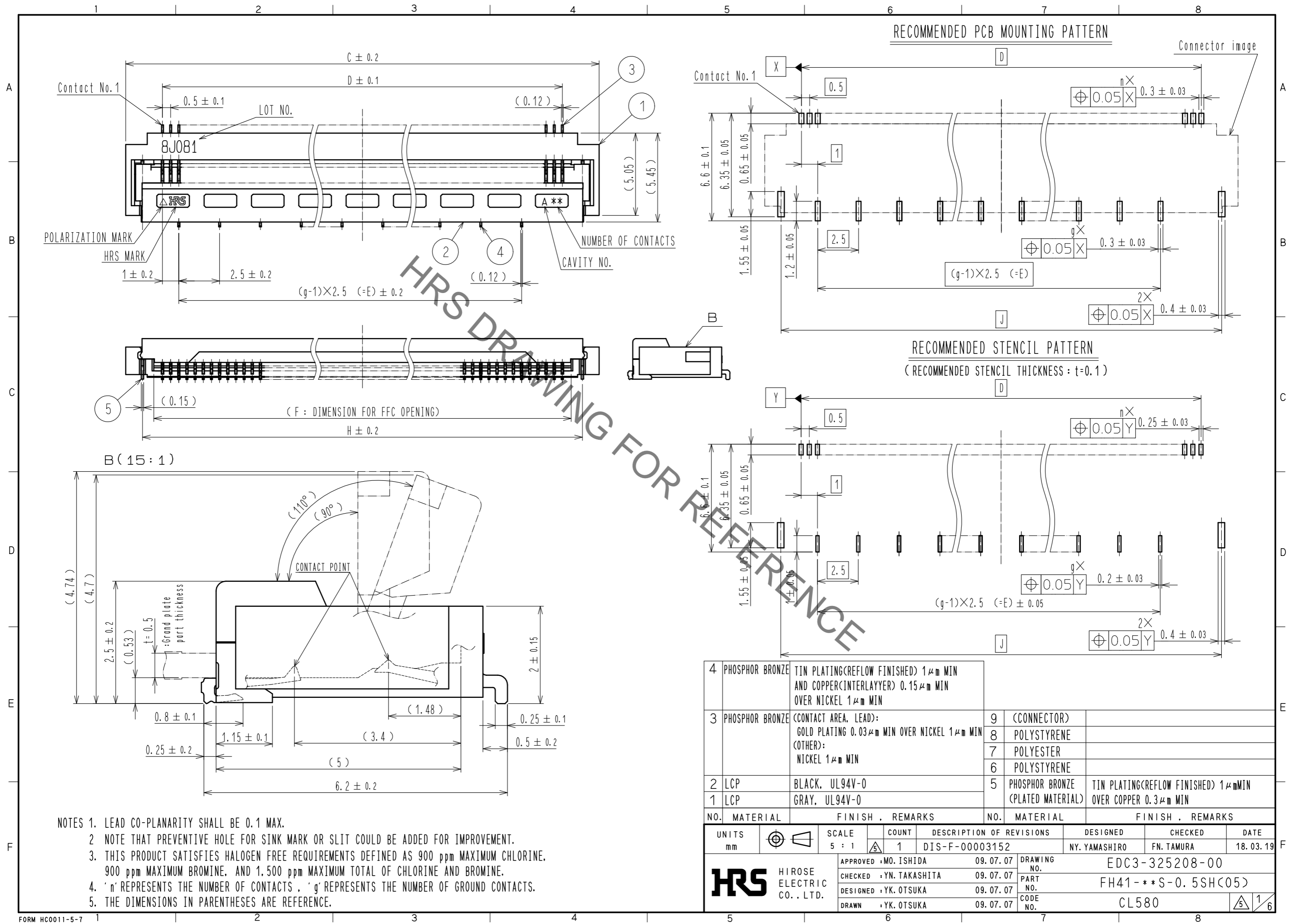

- NOTES
1. LEAD CO-PLANARITY SHALL BE 0.1 MAX.
  2. NOTE THAT PREVENTIVE HOLE FOR SINK MARK OR SLIT COULD BE ADDED FOR IMPROVEMENT.
  3. THIS PRODUCT SATISFIES HALOGEN FREE REQUIREMENTS DEFINED AS 900 ppm MAXIMUM CHLORINE, 900 ppm MAXIMUM BROMINE, AND 1,500 ppm MAXIMUM TOTAL OF CHLORINE AND BROMINE.
  4. 'n' REPRESENTS THE NUMBER OF CONTACTS, 'g' REPRESENTS THE NUMBER OF GROUND CONTACTS.
  5. THE DIMENSIONS IN PARENTHESES ARE REFERENCE.

4	PHOSPHOR BRONZE	TIN PLATING(REFLOW FINISHED) 1μm MIN AND COPPER(INTERLAYER) 0.15μm MIN OVER NICKEL 1μm MIN	9	(CONNECTOR)	
3	PHOSPHOR BRONZE	(CONTACT AREA, LEAD): GOLD PLATING 0.03μm MIN OVER NICKEL 1μm MIN (OTHER): NICKEL 1μm MIN	8	POLYSTYRENE	
2	LCP	BLACK, UL94V-0	7	POLYESTER	
1	LCP	GRAY, UL94V-0	6	POLYSTYRENE	
			5	PHOSPHOR BRONZE (PLATED MATERIAL)	TIN PLATING(REFLOW FINISHED) 1μm MIN OVER COPPER 0.3μm MIN

NO.	MATERIAL	FINISH	REMARKS	NO.	MATERIAL	FINISH	REMARKS

UNITS	mm	SCALE	5 : 1	COUNT	1	DESCRIPTION OF REVISIONS	DESIGNED	CHECKED	DATE
						DIS-F-00003152	NY. YAMASHIRO	FN. TAMURA	18.03.19
<b>HRS</b>		HIROSE ELECTRIC CO., LTD.		APPROVED	MO. ISHIDA	09.07.07	DRAWING NO. EDC3-325208-00		
				CHECKED	YN. TAKASHITA	09.07.07	PART NO. FH41-**S-0.5SH(C05)		
				DESIGNED	YK. OTSUKA	09.07.07	CODE NO. CL580		
				DRAWN	YK. OTSUKA	09.07.07	1/6		

Aug.1.2021 Copyright 2021 HIROSE ELECTRIC CO., LTD. All Rights Reserved.  
In case of consideration for using Automotive equipment / device which demand high reliability, kindly contact our sales window correspondents.

RECOMMENDED FFC (5:1)

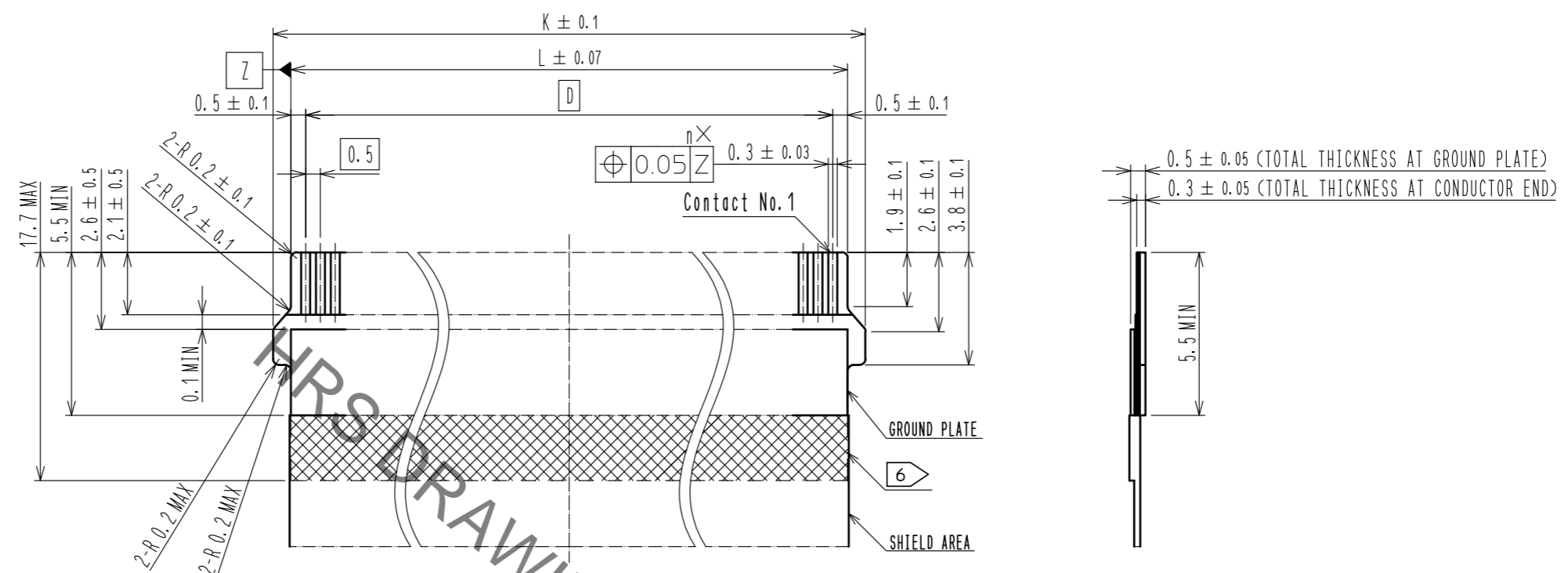

FFC CONFIGURATION (REFERENCE EXAMPLE) (SCALE:FREE)

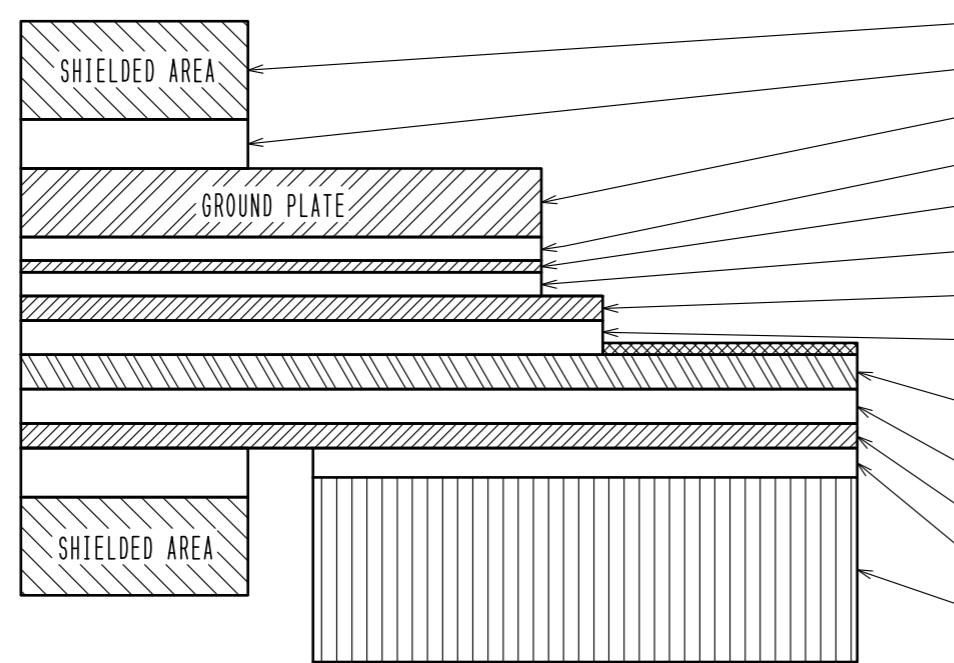

MATERIAL NAME	MATERIAL	TOTAL THICKNESS AT GROUND PLATE (μm)	TOTAL THICKNESS AT CONDUCTOR END (μm)
SHIELDING MATERIAL			
CONDUCTIVE ADHESIVE	POLYESTER TYPE		
COPPER FILM (TIN PLATED)		70	70
ADHESIVE	ACRYLIC TYPE	24	24
BASE MATERIAL	POLYESTER TYPE	12	12
ADHESIVE	ACRYLIC TYPE	24	24
INSULATED LAYER	POLYESTER TYPE	25	25
ADHESIVE	POLYESTER TYPE	35	35
SOFT COPPER FILM (NICKEL UNDER PLATED / GOLD PLATED)		35	35
ADHESIVE	POLYESTER TYPE	35	35
INSULATED LAYER	POLYESTER TYPE	25	25
ADHESIVE	POLYESTER TYPE	30	30
STIFFENER	POLYESTER TYPE	188	188
TOTAL		503	313

- NOTES
- 6 PLEASE OVERLAP SHIELD AREA ON GROUND PLATE.
  - 7 PLEASE INQUIRE OF HIROSE WHEN YOU WANT TO CHANGE THE SPECIFICATION AND THE THICKNESS COMPOSITION IN THIS PART.

<RECOMMENDED FFC>

<b>HRS</b>	DRAWING NO.	EDC3-325208-00
	PART NO.	FH41-**S-0.5SH<05>
	CODE NO.	CL580
		5/2/6

Aug.1.2021 Copyright 2021 HIROSE ELECTRIC CO., LTD. All Rights Reserved.  
 In case of consideration for using Automotive equipment / device which demand high reliability, kindly contact our sales window correspondents.

EMBOSSED CARRIER TAPE DIMENSION (2:1)

●24mm

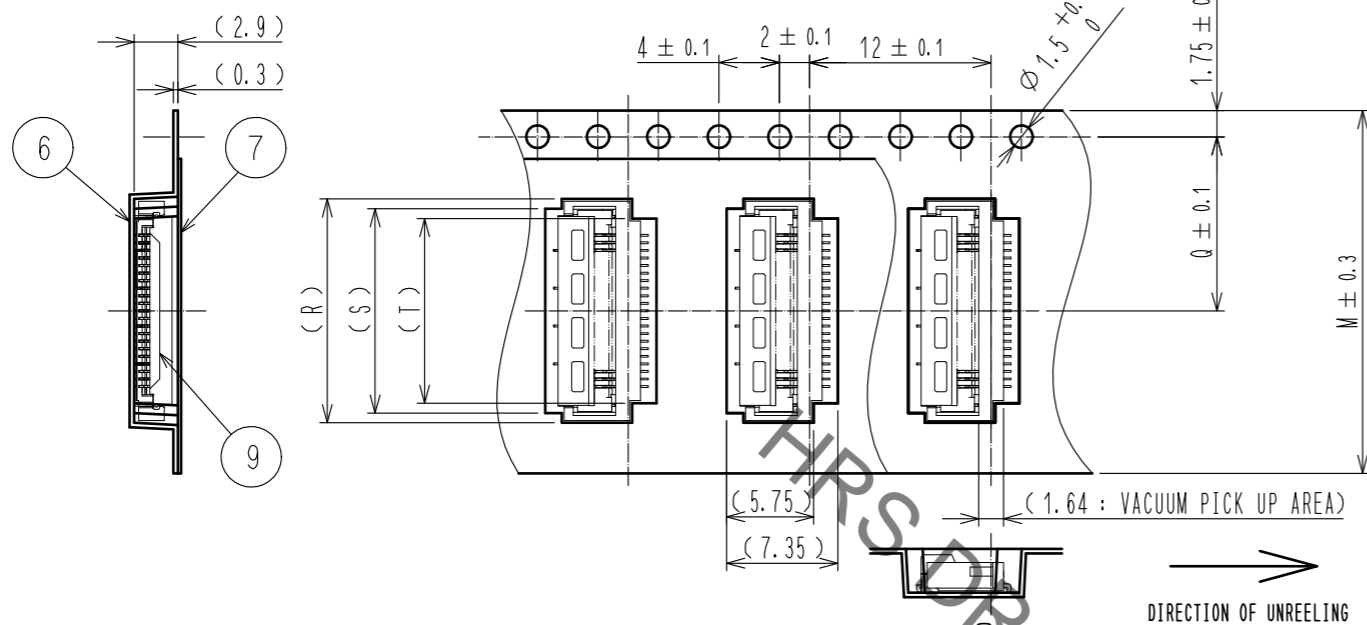

REEL DIMENSION (FREE)

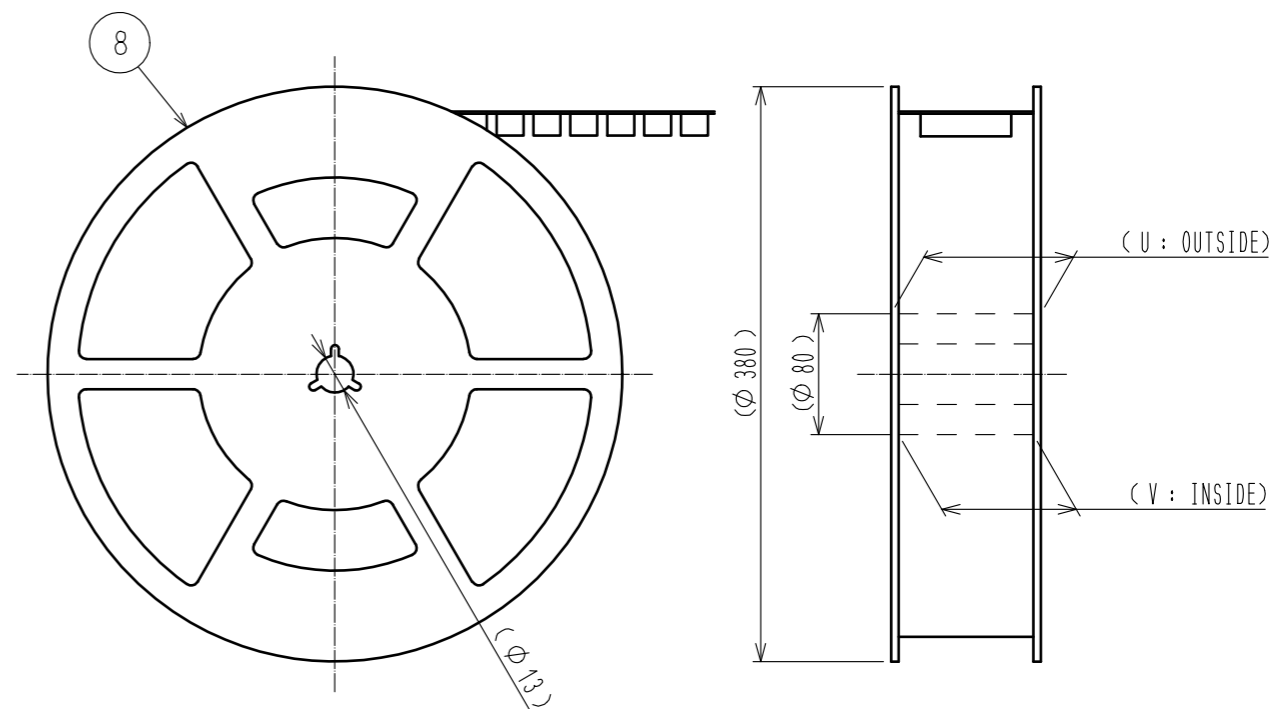

●32mm MIN

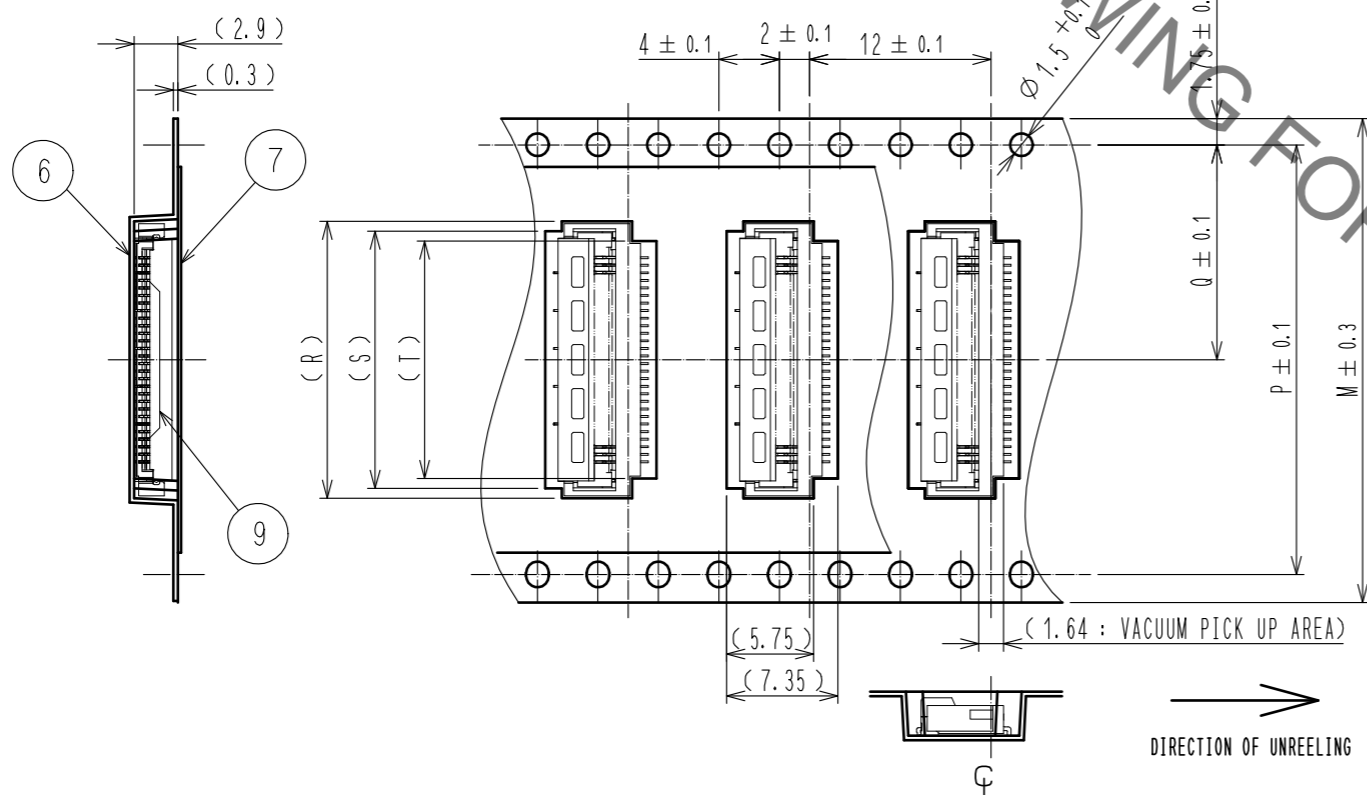

- NOTES  
 8. PER REEL: 2,500 CONNECTORS.  
 9. REFER TO IIS C 0806 AND IEC 60286-3(PACKING OF COMPONENTS FOR AUTOMATIC HANDLING.)

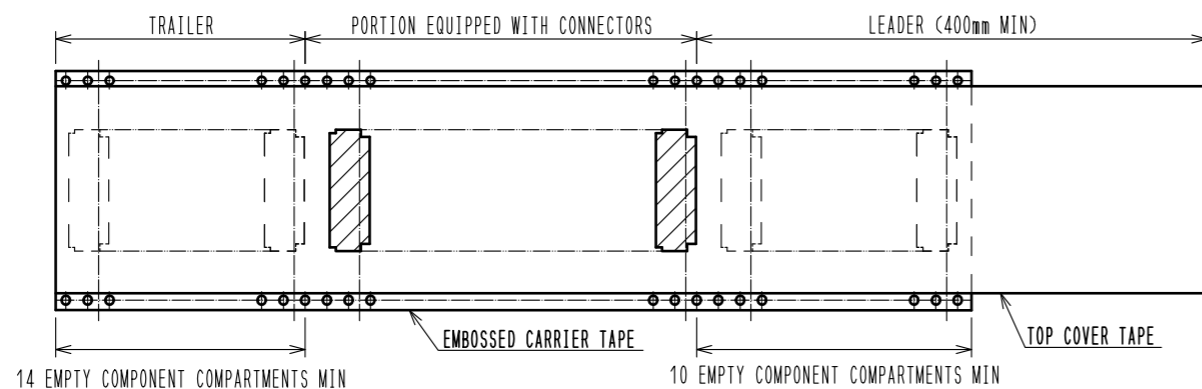

<DRAWING FOR PACKING>

<b>HRS</b>	DRAWING NO.	EDC3-325208-00
	PART NO.	FH41-**S-0.5SH(C05)
	CODE NO.	CL580
		3/6

Aug.1.2021 Copyright 2021 HIROSE ELECTRIC CO., LTD. All Rights Reserved.  
 In case of consideration for using Automotive equipment / device which demand high reliability, kindly contact our sales window correspondents.

PART NUMBER	CODE NUMBER	NUMBER OF CONTACTS	NUMBER OF GROUND CONTACTS : g	DIMENSION OF CONNECTOR, LAND PATTERN, METAL MASK AND FFC									DIMENSION OF DRAWING FOR PACKING						
				C	D	E	F	H	J	K	L	M	P	Q	R	S	T	U	V
FH41-15S-0.5SH(05)	CL580-2222-2-05	15	3	11.5	7	5	8.07	9.45	9.5	9.2	8	24	-	11.5	11.8	10.5	9.2	29.4	25.4
FH41-20S-0.5SH(05)	CL580-2221-0-05	20	4	14	9.5	7.5	10.57	11.95	12	11.7	10.5	24	-	11.5	14.3	13	11.7	29.4	25.4
FH41-28S-0.5SH(05)	CL580-2208-1-05	28	5	18	13.5	10	14.57	15.95	16	15.7	14.5	32	28.4	14.2	18.3	17	15.7	37.4	33.4
FH41-30S-0.5SH(05)	CL580-2218-5-05	30	6	19	14.5	12.5	15.57	16.95	17	16.7	15.5	32	28.4	14.2	19.3	18	16.7	37.4	33.4
FH41-31S-0.5SH(05)	CL580-2216-0-05	31	6	19.5	15	12.5	16.07	17.45	17.5	17.2	16	32	28.4	14.2	19.8	18.5	17.2	37.4	33.4
FH41-40S-0.5SH(05)	CL580-2205-3-05	40	8	24	19.5	17.5	20.57	21.95	22	21.7	20.5	44	40.4	20.2	24.3	23	21.7	49.4	45.4
⑩ FH41-50S-0.5SH(28)	CL580-2204-0-28	50	10	29	24.5	22.5	25.57	26.95	27	26.7	25.5	44	40.4	20.2	29.3	28	26.7	49.4	45.4
⑤ FH41-60S-0.5SH(05)	CL580-2223-0-05	60	12	34	29.5	27.5	30.57	31.95	32	31.7	30.5	56	52.4	26.2	34.3	33	31.7	61.4	57.4
⑩ FH41-68S-0.5SH(28)	CL580-2202-5-28	68	13	38	33.5	30	34.57	35.95	36	35.7	34.5	56	52.4	26.2	38.3	37	35.7	61.4	57.4

⑩ THE SPECIFICATION OF (28) IS APPLIED TO NUMBER OF CONTACTS 50 AND 68.

HRS DRAWING FOR REFERENCE

<b>HRS</b>	DRAWING NO.	EDC3-325208-00	
	PART NO.	FH41-**S-0.5SH(05)	
	CODE NO.	CL580	⑤ 4/6

Aug.1.2021 Copyright 2021 HIROSE ELECTRIC CO., LTD. All Rights Reserved.  
In case of consideration for using Automotive equipment / device which demand high reliability, kindly contact our sales window correspondents.

This connector requires delicate and careful handling.  
Read through the instructions shown below and handle the connector properly.  
Each values indicating here are for reference and may differ from standard value.

**[ INSTRUCTIONS FOR MOUNTING ON THE BOARD ]**

◆ **Warp of Board**

Minimize warp of the board as much as possible.  
Lead co-planarity is 0.1 mm or less.  
Too much warp of the board may result in a soldering failure.

◆ **Load to Connector**

Do not add 1N or greater external force when unreel or pick and place the connector etc.  
or it may get broken.  
In addition, do not insert the FFC or operate the connector before mounting it.

**[ INSTRUCTIONS FOR PCB HANDLING AFTER MOUNTING THE CONNECTOR ]**

◆ **Load to Board**

- Splitting a large board into several pieces  
- Screwing the board  
Avoid the handling described above so that no force is exerted on the board during the assembly process.  
Otherwise, the connector may become defective.

◆ **Amount of Warp**

The warp of a 100 mm wide board should be 1 mm or less.  
The warp of board suffers stress on connector and the connector may become defective.

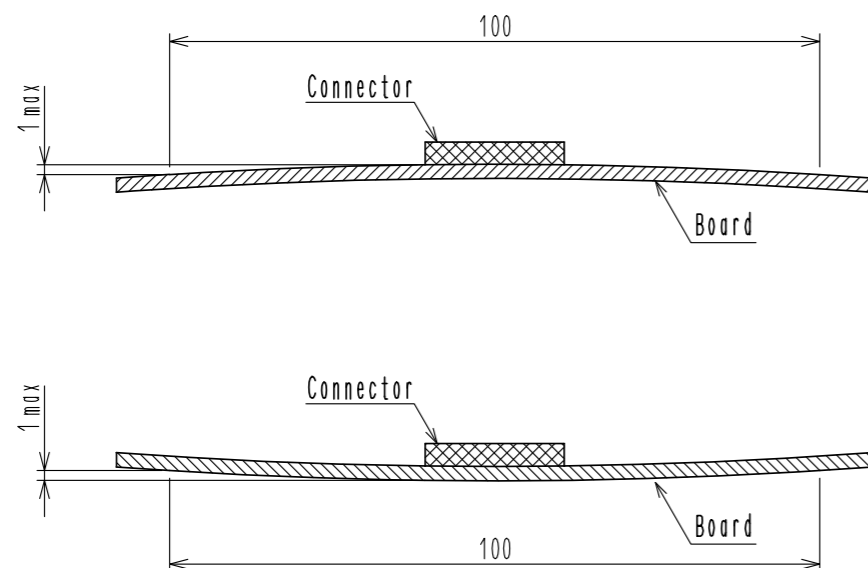

**[ INSTRUCTIONS ON INSERTING FFC AND CONNECTION ]**

◆ **Use of the Actuator**

1. Be very careful not to apply excessive force when releasing the actuator in the initial position.  
If you use your nail or finger as shown below, the terminals may be deformed.

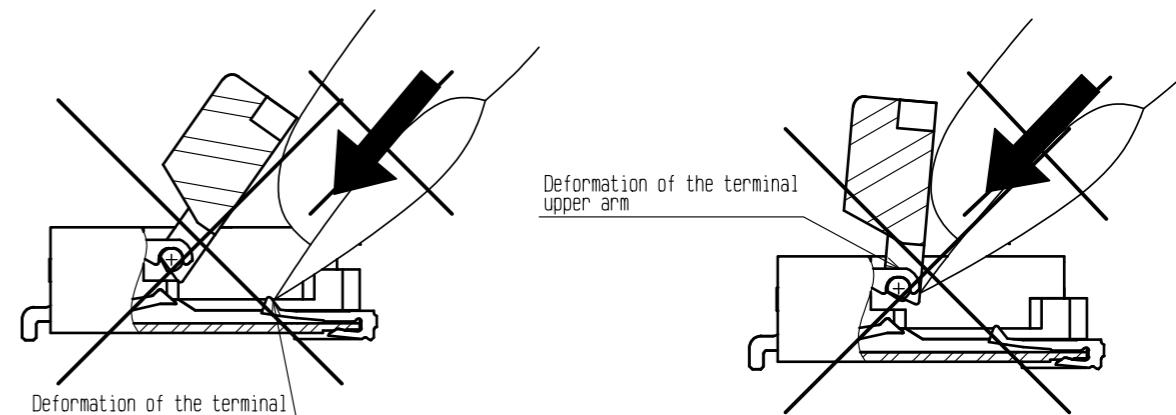

2. The actuator rotates around the rotational axis as shown below.  
Rotate the actuator.
3. The actuator will not open more than 110°.  
Do not apply any force backward beyond this point.  
Otherwise, the actuator may come off or break.

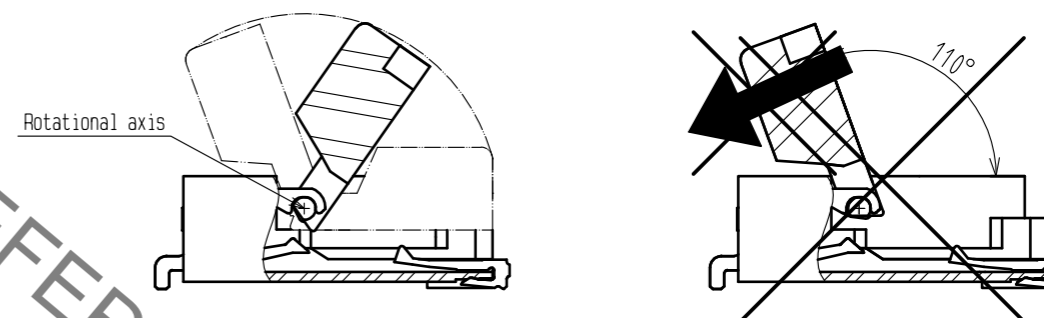

4. Move the actuator at approximately the center.
5. Do not pinch or pick the actuator to lift it as shown below. Otherwise, it may break.  
(Do not carry out any operation other than rotating the actuator as shown in 2 above.)

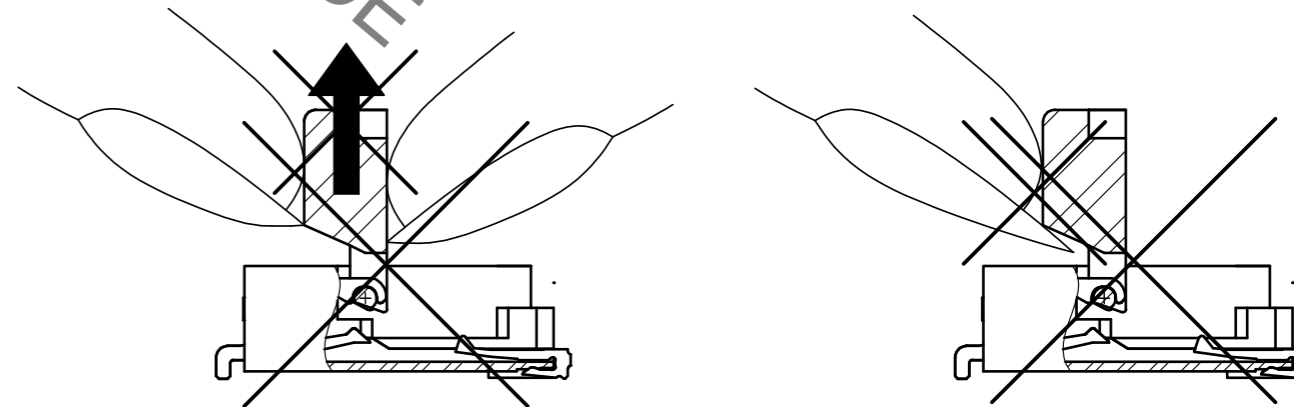

**< INSTRUCTION MANUAL (1) >**

<b>HRS</b>	DRAWING NO.	EDC3-325208-00
	PART NO.	FH41-**S-0.5SH<05>
	CODE NO.	CL580
		5/6

Aug.1.2021 Copyright 2021 HIROSE ELECTRIC CO., LTD. All Rights Reserved.  
In case of consideration for using Automotive equipment / device which demand high reliability, kindly contact our sales window correspondents.

◆ Direction of Contacts  
This connector has contacts on the bottom. Thus, insert FFC with the exposed conductors face down.

◆ Inserting the FFC  
1. Insert the FFC by about 8.5 degrees along the surface and at a right angle to the connector.  
Insert it properly to the very end.

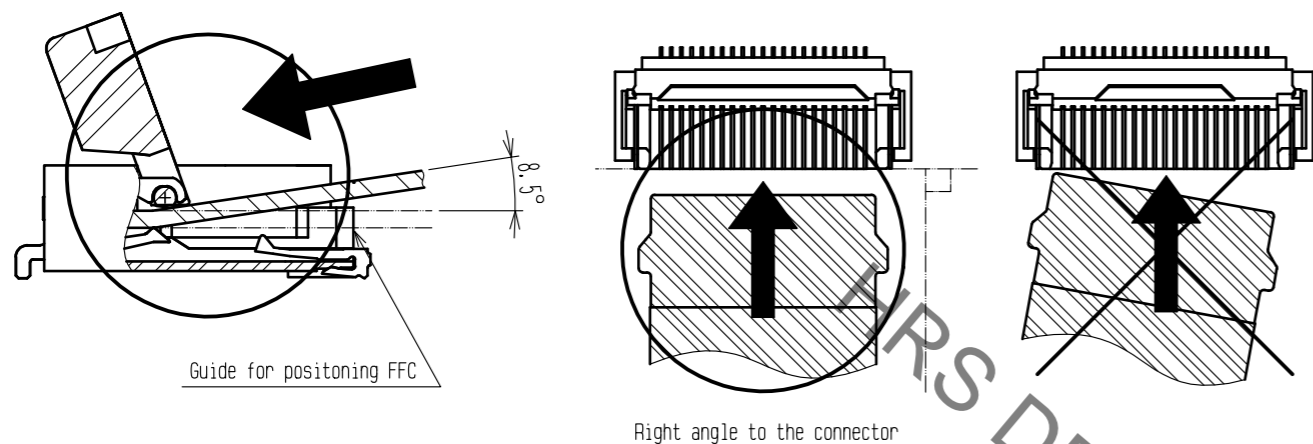

2. Do not insert the FFC diagonally from above.  
If the FFC is inserted at a slant (incorrectly) as shown below in the FFC insertion process, the edge of the FFC may catch in the terminals, resulting in deformation of the terminals. The FFC may bend and patterns may break or the FFC may not insert completely, resulting in improper conduction.

※ Keep a sufficient FFC insertion space in the stage of the layout in order to avoid incorrect FFC insertion.  
Besides, it is not difficult to insert FFC correctly all the way to the end.  
Design the proper layout of parts.

※ Make adjustments with the FFC manufacturer for FFC bending performance and wire breakage.

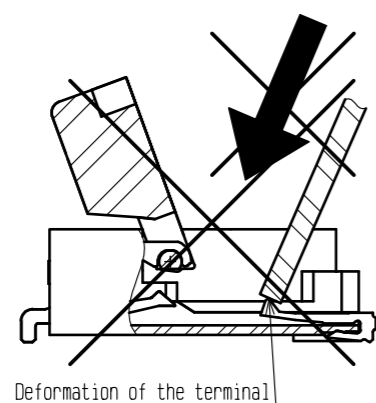

3. Do not rotate the actuator when FFC TAB is on right and left guides for positioning FFC.  
Make sure the position of FFC TAB and guides before rotate the actuator.

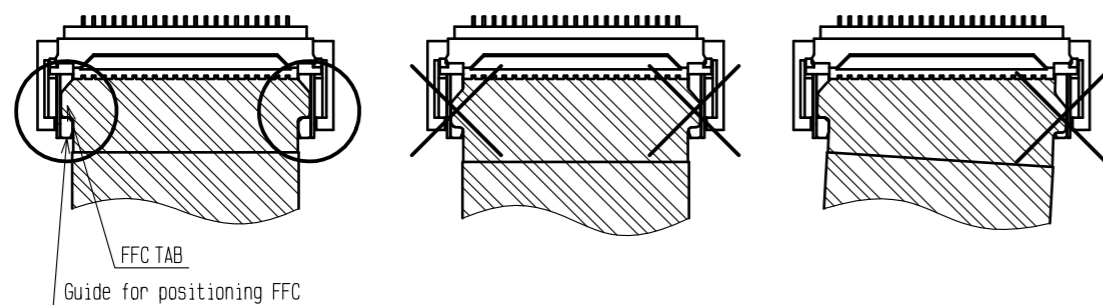

◆ Checking the Locking Condition  
In the locked condition, make sure that the actuator is horizontal on the board surface.  
Do not apply excessive force to it near the 0° position of the actuator.  
Otherwise, the terminals may be deformed.

[INSTRUCTIONS ON FFC LAYOUT AFTER CONNECTION]

◆ Load to FFC  
Be very careful not to apply any force to the connector directly after inserting FFC.  
Otherwise, the connector may become unlocked or the FFC may break.  
In particular, design the FFC layout with care not to bend it sharply upward in a vertical direction near the insertion opening.  
Fix the FFC when loads are applied to it continuously.

Load:  $0.05 \times n \text{ N MAX}$   
(n: number of contacts)

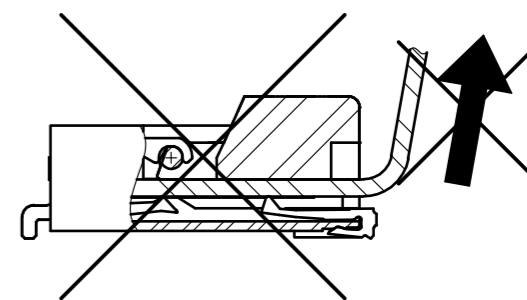

[INSTRUCTIONS ON REMOVING FFC]

◆ Move the actuator at approximately the center.  
◆ Release the actuator to remove the FFC.  
Remove the FFC by about 8.5 degrees along the surface.

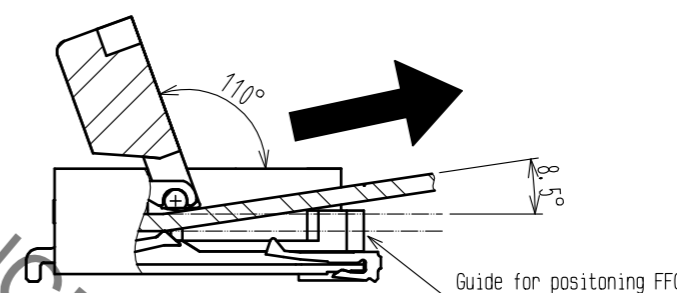

[OTHER INSTRUCTIONS]

◆ Instructions on Manual Soldering  
Follow the instructions shown below when soldering the connector manually during repair work, etc.  
1. Do not perform reflow soldering or manual soldering with the FFC inserted into the connector.  
2. Do not heat the connector excessively. Be very careful not to let the soldering iron contact any parts other than connector leads. Otherwise, the connector may be deformed or melt.  
3. Do not use excessive solder (or flux).  
If excessive solder (or flux) is used on the terminals, solder or flux may adhere to the contacts or rotating parts of the actuator, resulting in poor contact or a rotation failure of the actuator. Supplying excessive solder to the reinforcing bracket may hinder actuator rotation, resulting in breakage of the connector.

< INSTRUCTION MANUAL(2) >

<b>HRS</b>	DRAWING NO.	EDC3-325208-00
	PART NO.	FH41-**S-0.5SH<05>
	CODE NO.	CL580
		5/6

# Mouser Electronics

Authorized Distributor

Click to View Pricing, Inventory, Delivery & Lifecycle Information:

[Hirose Electric:](#)

[FH41-40S-0.5SH\(05\)](#)